

FreedomChair  
**Mobility Scooter S1**  
User Manual



## Table of Contents

<b>Warnings and Precautions</b> .....	<b>1</b>
<b>*Please read this content before use*</b> .....	<b>1</b>
Limitations of the user.....	1
Warnings and Precautions to Observe .....	1
<b>Chapter 1. Foreword</b> .....	<b>2</b>
<b>1.1 Copyright</b> .....	<b>2</b>
<b>1.2 Statements</b> .....	<b>2</b>
<b>1.3 Manufacturers' guarantees</b> .....	<b>2</b>
<b>1.4 Cautions</b> .....	<b>2</b>
<b>1.5 Basic product information</b> .....	<b>2</b>
<b>Chapter 2. Overview</b> .....	<b>3</b>
<b>2.1 Product Features and principles</b> .....	<b>3</b>
<b>2.2 Scope of application</b> .....	<b>3</b>
<b>2.3. Main structure</b> .....	<b>3</b>
<b>2.4. Main technical specifications</b> .....	<b>4</b>
2.4.1 Manufacturer testing information .....	4
<b>2.5 Conditions of use</b> .....	<b>4</b>
<b>2.6 Storage conditions</b> .....	<b>4</b>
<b>Chapter 3. Security</b> .....	<b>5</b>
<b>3.1 Identifier descriptions</b> .....	<b>5</b>
3.1.1 Packaging and transport marking descriptions .....	5
3.1.2 Label identification symbol descriptions.....	5
<b>3.2. Classification of security types</b> .....	<b>5</b>
<b>Chapter 4. Use and Operation</b> .....	<b>6</b>
<b>4.1 How to open and fold the mobility scooter</b> .....	<b>6</b>
<b>4.2 Anti-tipper wheels</b> .....	<b>6</b>
<b>4.3. Battery installation and replacement</b> .....	<b>7</b>
<b>4.4 Armrest flip-up function</b> .....	<b>7</b>
<b>4.5 Electric and manual push function</b> .....	<b>7</b>
<b>4.6 Seat height adjustment</b> .....	<b>8</b>
<b>4.7 First operation of the mobility scooter</b> .....	<b>8</b>
<b>Chapter 5. The Controller</b> .....	<b>9</b>
<b>5.1 Main functions of the controller</b> .....	<b>9</b>
<b>5.2 Main display description</b> .....	<b>9</b>
5.2.1 Main display panel.....	9
<b>5.3 Left and right handle controls</b> .....	<b>9</b>
5.3.1 Left handle button combination.....	9
5.3.2 Right handle button combination .....	9

<b>5.4 Remote control key</b> .....	<b>10</b>
5.4.1 Remote control key.....	10
<b>5.5 Operation button table:</b> .....	<b>10</b>
<b>5.6 Controller components</b> .....	<b>10</b>
<b>5.7 Display Interfaces</b> .....	<b>11</b>
<b>5.8 Functions of Controller</b> .....	<b>12</b>
5.8.1 Power on and off .....	12
5.8.2 Driving.....	12
5.8.3 Emergency brake .....	12
5.8.4 Scooter platform lengthen and shorten function .....	12
5.8.5 Battery level indicator .....	12
5.8.6 Horn and headlight function .....	12
5.8.7 Turning light function .....	13
5.8.8 Brake light function .....	13
5.8.9 Differential function .....	13
5.8.10 Turning speed function.....	13
5.8.11 Power on self-test function .....	13
5.8.12 Brake function .....	13
5.8.13 Energy recovery.....	13
5.8.14 Automatic power off .....	13
<b>5.9 Controller Configuration</b> .....	<b>14</b>
5.9.1 Parameter Table.....	14
<b>5.10 Remote control key learning function</b> .....	<b>15</b>
<b>5.11 Controller Troubleshooting</b> .....	<b>16</b>
5.11.1 Faults and troubleshooting methods .....	16
<b>Chapter 6. Battery charging</b> .....	<b>18</b>
<b>6.1 Preferred Charging Method</b> .....	<b>18</b>
<b>6.2 Alternative Charging Method</b> .....	<b>18</b>
<b>6.3 Charger Indicator Light</b> .....	<b>18</b>
<b>6.4 Automatic Charger Switch Off</b> .....	<b>18</b>
<b>Chapter 7. Storage and transportation of mobility scooters</b> .....	<b>19</b>
<b>7.1 Folding</b> .....	<b>19</b>
<b>7.2 Lifting</b> .....	<b>19</b>
<b>7.3 Storage in a Vehicle</b> .....	<b>19</b>
<b>7.4 Storage on Public Transport</b> .....	<b>19</b>
<b>Chapter 8. Service and maintenance of mobility scooter</b> .....	<b>20</b>
<b>8.1 Routine inspection and maintenance</b> .....	<b>20</b>
<b>8.2 Replacement of consumable parts for mobility scooters</b> .....	<b>20</b>
<b>8.3 Cleaning and disinfection</b> .....	<b>21</b>
<b>Chapter 9. Troubleshooting</b> .....	<b>21</b>
<b>9.1 Fault phenomena and troubleshooting methods</b> .....	<b>21</b>
<b>Chapter 10. Mobility Scooter Parts</b> .....	<b>22</b>
<b>10.1 Complete vehicle parts diagram</b> .....	<b>22</b>
<b>10.2 Names of vehicle components</b> .....	<b>23</b>

<b>10.3 Electrical schematics .....</b>	<b>24</b>
<b>10.4 Specifications of the Controller.....</b>	<b>25</b>
10.4.1 Revisions .....	25
<b><i>Chapter 11. Environmental protection .....</i></b>	<b>26</b>
11.1 Name and content of toxic or hazardous substances or elements.....	26
11.2 Treatment at the end of product service life.....	26
<b><i>Chapter 12. Quality assurance .....</i></b>	<b>26</b>
Product Warranty.....	26
Warranty card.....	27
Manufacturer’s details .....	27
UK & Ireland Distributor .....	27

## Warnings and Precautions

**\*Please read this content before use\***

### Limitations of the user

The user must be of sound mind and judgment, must not be unresponsive in their upper limbs, or who are unable to use the scooter as prescribed by a physician.

### Warnings and Precautions to Observe

To ensure the safe operation of your mobility scooter and to ensure its longevity, turn off the power when the scooter is not in use, and read and observe the following precautions.

1. Do not operate the mobility scooter without first reading the manual.
2. The total weight of persons and objects may not exceed the maximum permissible load (see nameplate).
3. The maximum permissible slope cannot be exceeded.
4. Do not go uphill or downhill at maximum speed or you risk rolling over and losing control.
5. Don't drive on very slippery or soft surfaces.
6. Do not drive on slopes without guardrails
7. Do not drive on the highway.
8. Do not swerve or drive sideways on ramps or risk rolling over.
9. Reverse with caution on a ramp, or you're in danger of rolling over.
10. Do not climb over the maximum permissible height.
11. Don't pull cargo.
12. Please use the mobility scooter with your seat belt fastened.
13. Keep your feet and hands on the pedals and handrails at all times when using the mobility scooter.
14. When you are new to using a mobility scooter, please practice in an open area before using in more confined areas.
15. Concentrate and don't be distracted while the mobility scooter is moving.
16. Please use the crosswalk when crossing the street.
17. Please pay attention to the battery indicator when driving a mobility scooter.
18. Do not cross the road when the battery is low, to avoid the danger of running out of power in the middle of the road.
19. If the mobility scooter is not used for a long time, it should be folded and stored in a dry and ventilated place.
20. The mobility scooter should not be stored in a high temperature and humidity environment.

## Chapter 1. Foreword

### 1.1 Copyright

This publication, including all photographs and illustrations, is protected by international copy laws and all copyrights are owned by us.

Version: V1.0

P/N No.: OSD-2020-01

### 1.2 Statements

- We reserve the right to revise the content of this document without notice.
- Some of the pictures in this instruction manual are schematics, so please refer to the actual product if there are any differences.

### 1.3 Manufacturers' guarantees

- Our company guarantees free maintenance and replacement of non-manipulated damaged parts during the warranty period.
- This warranty applies only to the range of conditions specified in the operating instructions.
- This warranty does not cover damage caused by external causes such as lightning strikes, earthquakes, theft, improper use or abuse, or alterations.
- In the event of a problem with a product, please notify your retailer promptly of the product model, serial number, date of purchase, and the specific problem.

### 1.4 Cautions

To ensure the safety and long-term stability of the product, please read this manual carefully before use to fully understand its function, operation and maintenance.

Improper handling or failure of the user to follow the manufacturer's or its agent's instructions may result in product damage or even personal injury.

### 1.5 Basic product information

- Product Name: FreedomChair Scooter S1
- Model specifications: see section 2.4 of this instruction manual
- After-sales service information: see section 7 of this instruction manual

## Chapter 2. Overview

### 2.1 Product Features and principles

- Using 2 powerful DC brushless motors, which have the advantage of low noise, high torque, energy saving and high efficiency, maintenance free and long life.
- Using lithium-ion battery energy, which has the advantages of high energy density and long life.
- Using a brushless special intelligent controller, which has the advantages of easy and free operation and accurate positioning.
- Adopting the foldable multi-link frame structure (patented), which has the advantages of fast folding, safety and reliability, easy operation, and compact portability.

This product is mainly composed of frame, wheels, seat, armrest, battery, motor and controller, powered by lithium battery, the controller and 2 left and right brushless motors control the speed and direction of the wheelchair carriage.

### 2.2 Scope of application

Mobility for the disabled, the sick and the elderly with mobility problems

### 2.3. Main structure

The mobility scooter mainly consists of a frame, wheels, seat, armrests, battery, motor and controller, as shown below.



## 2.4. Main technical specifications

- Total length 1080-1230mm  $\pm 5$ mm (Base frame is extendable) Folded length 1080 $\pm 5$ mm
- Total width 640mm  $\pm 5$ mm Folded width 640mm  $\pm 5$ mm
- Total height 920mm  $\pm 5$ mm Folded height 530mm  $\pm 5$ mm
- Total weight: 38kg $\pm 1$ kg
- Downhill static stability: 20 $^{\circ}\pm 1^{\circ}$
- Static stability uphill: 15 $^{\circ}\pm 1^{\circ}$
- Lateral static stability: 16 $^{\circ}\pm 1^{\circ}$
- Energy consumption: 2.4 $\pm 0.5$ kw-h/100km
- Dynamic stability uphill: 10 $^{\circ}\pm 1^{\circ}$
- Obstacle-crossing ability: 40mm $\pm 5$ mm
- Maximum forward speed: 7 $\pm 0.5$ km/h
- Minimum braking distance at maximum speed: 1.0m $\pm 0.5$ m
- Minimum turning radius: 800mm $\pm 5$ mm
- Seat plane angle: 3 $^{\circ}\pm 1^{\circ}$  Effective seat depth: 375mm $\pm 5$ mm
- Effective seat width: 430mm $\pm 5$ mm Front seat surface height: 470-510mm $\pm 5$ mm (seat height adjustable)
- Backrest angle: 12 $^{\circ}\pm 1^{\circ}$  Backrest height: 760mm
- Distance from armrest to seat: 160mm $\pm 5$ mm Distance from front armrest to backrest: 335mm $\pm 5$ mm
- Front and rear wheelbase; 765-915mm $\pm 5$ mm (base frame can be contracted)
- Maximum load capacity: 120kg
- Front and rear wheel size: 12"\*3.5" pneumatic tires.
- Motor parameters: DC motor rated voltage 24V, rated power 250Wx2

### 2.4.1 Manufacturer testing information

Model: S1 Mobility Scooter

Test dummy mass: 110Kg

Maximum user mass: 110Kg

## 2.5 Conditions of use

Ambient temperature: -20 $^{\circ}\text{C}$ ~50 $^{\circ}\text{C}$

Relative humidity: 20%~80%

Atmospheric pressure: 860hPa~1060hPa

No strong electromagnetic interference

## 2.6 Storage conditions

The packed wheelchairs should be stored in a well-ventilated room at a temperature of -30 $^{\circ}\text{C}$ ~65 $^{\circ}\text{C}$ , relative humidity not exceeding 95%, atmospheric pressure of 560~1060hPa, without harmful gases that can cause corrosion, and should not be stacked under heavy pressure.



## Chapter 3. Security

### 3.1 Identifier descriptions

#### 3.1.1 Packaging and transport marking descriptions



Fragile



Stacked layer limit

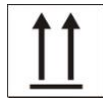

Upward



Keep Dry

#### 3.1.2 Label identification symbol descriptions



Protective grounding



Check accompanying document



Type B application section

IPX3

Showerproof showering  
Within 60° of each vertical surface  
has no effect

### 3.2. Classification of security types

- By type of protection against electric shock: internal power supply category.
- By degree of protection against electric shock: Type B application part.
- Classified by degree of protection against the ingress of fluids: IPX3.
- Classified according to the degree of safety when used in the presence of flammable anaesthetic gases mixed with air or flammable anaesthetic gases mixed with oxygen or nitrous oxide: non-AP or APG.
- Classified by mode of operation: continuous operation.
- Rated voltage and frequency of equipment: DC24V.
- Whether the equipment has an application component that protects against the effects of defibrillation discharges: not applicable.
- Whether the equipment has a signal output or input section: not applicable.
- Permanently installed or non-permanently installed equipment: Non-permanently installed equipment

## Chapter 4. Use and Operation

### 4.1 How to open and fold the mobility scooter

4.1.1 Opening the mobility scooter: use one hand to hold the backrest, the other hand to hold the seat cushion and push open, as shown in Figure 1. Fasten the locking latch under the backrest after fully unfolded, as shown in Figure 2 (**before using the mobility scooter you must ensure that the locking latch has been pressed in place, otherwise there is a danger of folding whilst in use!**)



Fig. 1



Fig 2

4.1.2 Folding the mobility scooter: first release the locking latch, as shown in Figure 3. With one hand to hold the backrest, the other hand to pull the seat cushion closed, as shown in Figure 4.



Fig. 3



Fig 4

### 4.2 Anti-tipper wheels

When the scooter is in the normal driving mode, the anti-tipper wheel is in the state as figure 5. When the scooter is packed or when folded to make it stand up, fold down the anti-tipper as shown in figure 6.



Fig. 5



Fig 6

### 4.3. Battery installation and replacement

4.3.1 Insert the power lead into the battery and tighten it, as shown in Figure 7. To remove the battery, loosen and pull out the power lead, as shown in Figure 8, then press the sprung-loaded catch under the battery and slide out.



Fig. 7



Fig 8

### 4.4 Armrest flip-up function

Turn the armrest locking knob upward as shown in Figure 9, then lift the armrest upward as shown in Figure 10. To lock the armrest in the down position, rotate the locking knob downwards.



Fig. 9



Fig 10

### 4.5 Electric and manual push function

When the red lever on the motor is pulled backward, it is in electric mode, and when it is pressed forward, it is in manual (freewheel) mode, as shown in Figure 11, **Note: In electric mode, the handle must be pulled backwards, otherwise the controller will sound an alarm and the scooter will not start. In manual mode, the power should be turned off, otherwise the implementation resistance will be great.**



Fig 11

#### 4.6 Seat height adjustment

Under the front of the seat, there is a cable which can be pulled to release the seat frame which can then be adjusted to suit the height of the user (Fig 12). The height is adjustable by combining the sliding mechanism at the rear of the seat together with the different height positions of the locking pins at the front of the seat. When the desired height is set, ensure that both locking pins at each end of the cable are securely in position.



Fig 12

#### 4.7 First operation of the mobility scooter

Before sitting on the scooter, the power must be turned off. It is recommended that an assistant accompanies the user until they become familiar with the controls.

**NOTE: refer to the instructions for the controller in the next section before operating the scooter.**

## Chapter 5. The Controller

The controller controls the forward, backward and turning of the scooter by independently controlling two brushless motors. The controller can realize differential functions by two motors speed difference control. Automatic speed down during turning. Which improves the driving comfort and safety.

### 5.1 Main functions of the controller

- Scooter forward and backward control
- Automatic control of electromagnetic brakes on motors providing ramp parking function
- Display function of speed, gear, fault status, etc.
- Electrically controlled wheelbase length function
- Configuration function for personalized configurations
- Power on self-check and fault alarm
- Lighting control, including turning light, brake light, tail light and headlight control
- Horn control
- Remote control function to for locking and unlocking the controller

### 5.2 Main display description

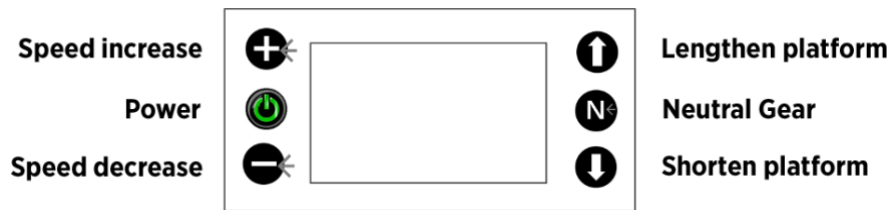

5.2.1 Main display panel

### 5.3 Left and right handle controls



5.3.1 Left handle button combination



5.3.2 Right handle button combination

## 5.4 Remote control key



5.4.1 Remote control key

## 5.5 Operation button table:

Name	Function Description
Power switch	Power on off control
Speed increase button	Speed gear control up
Speed decrease button	Speed gear control down
Lengthen platform button	Lengthen the scooter's wheelbase
Shorten platform button	Shorten the scooter's wheelbase
Neutral gear	Neutral gear on/off switching
Battery Level	Indicates the current battery level
Accelerator	Scooter drive control. More rotation increases speed
BRAKE	Emergency stop button.
Headlight	Switches headlight and tail light on/off
Left / Right Indicator	Switches the rear turn signals
Horn	Press to sound the horn
Reversing button	Forward and reverses switch button
Remote control lock button	Remote control scooter locking
Remote control unlock button	Remote control scooter unlocking

## 5.6 Controller components

Motor Controller (MController)  
 Display control module  
 Angle detection module  
 Headlight horn module  
 Tail light module  
 Wire harness  
 Remote control

## 5.7 Display Interfaces

The controller includes 3 display interfaces and a power-up welcome interface.

Following the welcome interface on power-up, the normal display interface is shown after about 2 seconds. The display interface can show the normal display interface, fault display interface and configuration test display interface.

The normal display interface displays the real-time speed, gear information, turning light status and headlight status.

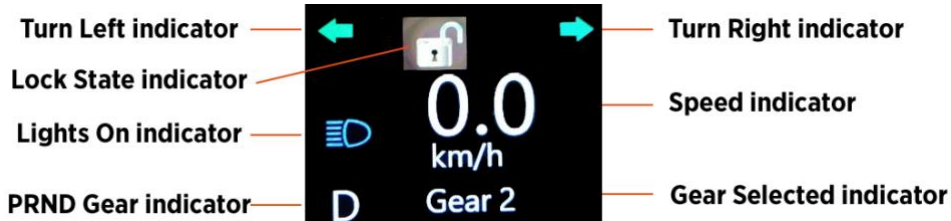

The fault display interface displays the battery voltage, scooter speed gear information and fault information. It can show up to 3 faults when multiple faults occur. This interface is displayed in the event of a system failure.

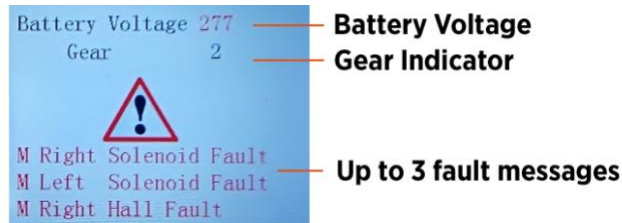

The configuration test display interface displays the steering turning angle, battery voltage, and the configuration parameter name and parameter value. This interface is displayed when the controller enters the configuration test state.

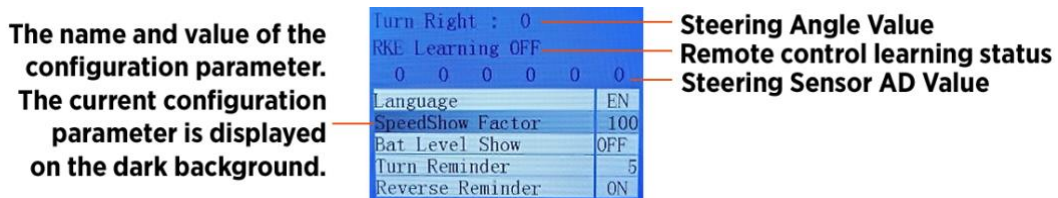

## 5.8 Functions of Controller

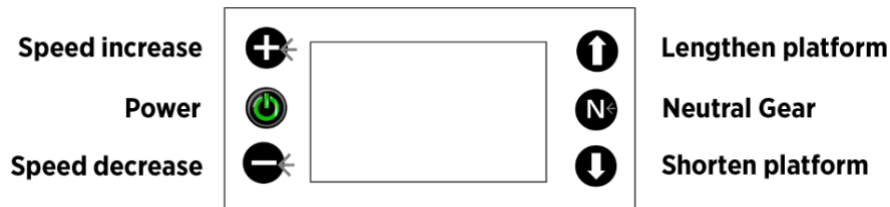

### 5.8.1 Power on and off

Power switch controls power to the controller and will switch the scooter on off. The screen lights up when the controller is in on state and goes off when the controller is in off state.

The remote control key can also control power to the controller. Lock button can lock and turn off the controller. Unlock button can unlock and turn on the controller.

It is recommended to turn off the controller when stationary for a long time to avoid consuming battery power.

### 5.8.2 Driving

**NOTE: when power is turned on, the parking gear (P) is automatically selected to prevent the scooter from accidentally moving until the user is prepared for their journey. To select drive mode (D), press the red BRAKE button on the left handle controller.**

With Power on and Drive gear selected (D), push the Accelerator lever to move the scooter forward. To go backwards, press the reverse button on the right handle controller and then use the Accelerator lever. Releasing the Accelerator lever will gradually bring the scooter to a stop. In P gear the Accelerator lever cannot be used to move the scooter.

The speed up and down buttons are used to adjust the speed gear from 1 (slowest setting) to 5 (fastest setting).

After pressing Neutral button for more than 1 second, the scooter enters freewheel mode. The electromagnetic brakes unlock the motors, and the scooter can be move freely. Press the key for more than 1 second again or press the red BRAKE button to exit the free move mode.

If the scooter is stationary for a long period of time, it will go into P gear again. The delay time before the scooter goes into P gear is configurable.

The display shows the current PRDN gear and speed selected. D = Forward, R = Reverse, P = Park, and N = Neutral (freewheel).

When the controller in the locked state, the scooter cannot switch to N gear.

### 5.8.3 Emergency brake

When an emergency brake is needed, press the emergency red BRAKE button. At this time, regardless of the position of the acceleration knob, the scooter will slow down and stop at a faster rate.

### 5.8.4 Scooter platform lengthen and shorten function

To expand and contract the scooter's wheelbase, use the Lengthen button and Shorten button on the display panel. After pressing the corresponding button for 1 second, the scooter starts to expand or contract, and stops immediately after releasing the button.

When the scooter speed is not 0, the expand and contract function cannot be used.

### 5.8.5 Battery level indicator

The three lights in the right handle button combination indicator the battery level. More lights illuminated = higher battery capacity. Please charge the battery in time when the battery indicator is low.

### 5.8.6 Horn and headlight function

When the horn switch is pressed, the horn will sound and stop when it is released.



When the headlight switch is turned on, the headlight and the tail light are turned on at the same time. When the headlight switch is turned off, the headlight and the tail light are turned off at the same time. The headlight indicator on the panel indicates the headlight state. The backlight brightness of the panel decreases when the headlight is turned on and increases when the headlight is turned off.

#### 5.8.7 Turning light function

The left turning light flashes when the turning switch is turned to the left, the right turning light flashes when the turning switch is turned to the right, and the corresponding indicator light on the rear light panel also flashes. When the turning switch is set in the middle, neither of the turning lights is on.

When the turning light flashes, there is also an audible warning.

#### 5.8.8 Brake light function

In the power on state, when the Accelerator lever is not pushed, the scooter is either parked or decelerating and the brake light automatically illuminates.

#### 5.8.9 Differential function

The controller measures the steering angle of the scooter and controls the difference in speed between of the left and right motors according to this angle. This helps to prevent either of the drive wheels from scuffing during turning, thus making turning smoother.

#### 5.8.10 Turning speed function

When the scooter turns, the speed of the scooter decreases corresponding to the steering angle, thus reducing the risk of rollover caused by high-speed turning of the scooter.

#### 5.8.11 Power on self-test function

After the controller is power on, self-inspection of the control system will take place. If the self-inspection fails and reports an error, the scooter cannot run. The self-inspection items include the communication function of controller, Hall state of motor and electromagnetic brake. See the chapter on controller troubleshooting for specific fault types.

#### 5.8.12 Brake function

The controller and the motor are matched with electronic braking and electromagnetic braking functions. In downhill or other similar situations, the controller generates an electronic brake function through the motor to limit the speed of the scooter, and also enables the scooter to stop quickly through the electronic brake function. In the parking state, the electromagnetic brake locks the motors to enable the parking function. When the scooter is moving, the electromagnetic brake unlocks the motors.

#### 5.8.13 Energy recovery

When the electronic brake operates, the motor works in regeneration mode, charging the battery to recover energy.

#### 5.8.14 Automatic power off

If the scooter is stationary for a long period of time, it will go into P (Parking) gear. The delay time before the scooter goes into P gear is configurable. Config to zero disables the automatic power off function.

## 5.9 Controller Configuration

Characteristics of the scooter can be adjusted to satisfy different users' preferences by configuration of some of its parameters.

**\*\* NOTE: changing the scooter's parameters is done entirely at the risk of the user. The national distributor or reseller of the scooter cannot be held responsible for any damage caused to the scooter's components or any injury to the user caused by changes that could affect the safe operation of this transportation device. \*\***

Before making any changes to a parameter, it is recommended to make a note of the parameter's value so that it can be restored to its original setting.

In the power off state, press the **⏻** button and **⏻** button at the same time, then press the power switch **⏻** to turn on the controller and enter the parameter configuration mode. Now release all buttons.

The **⏻** and **⏻** buttons select the configuration parameter. The **➕** and **➖** buttons are then used to change the parameter's value.

To exit configuration mode, press the power switch **⏻** to turn off the power.

The name and value of the configuration parameter. The current configuration parameter is displayed on the dark background.

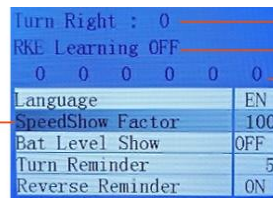

Steering Angle Value  
Remote control learning status  
Steering Sensor AD Value



The specific parameters that can be configured are as follows:



### 5.9.1 Parameter Table

No	Parameter Name	Parameter Description
0	Language	Set the display language.
1	Speed unit	Set the speed unit km/h or MPH
2	Speed factor	Due to difference motor and wheel diameter, it is necessary to make the display speed consistent with the actual speed through this coefficient setting.
3	Battery level show	Set the battery level display on and off on the panel.
4	Turning light warning	Set the warning tone on or off when the turning light flashes
5	Reverse warning	Set the warning tone on or off when reversing the scooter.
6	Power on off sound	Set the warning tone on or off when power switch.
7	Stop to P Shift time	Set the delay time of scooter switching to P (Parking) mode. The unit value in minutes. Zero means disable the function.
8	Auto shutdown time	Set the delay time of scooter shutting down. The unit value in minutes. Zero means disable the function.
9	Max Speed in forward	Set the maximum forward speed of the scooter
10	Max Speed in reverse	Set the maximum reverses speed of the scooter
11	Acceleration rate	Set the acceleration of the scooter

12	Dec rate in normal	Set the deceleration when the red BRAKE button is not pressed
13	Dec rate in BRAKE	Set the deceleration when the red BRAKE button is pressed
14	Diff speed by turn	Set the differential speed between the two wheels when the scooter turns
15	Speed down during turning	Set the reduction value of the maximum speed when the scooter turns.
16	Solenoid release time	Set the delay time for the lock of the electromagnetic brake after the scooter speed drops to 0
17	Solenoid failure mask	Set the electromagnetic brake failure alarm or not. In order to realize the slope-to-parking function, this setting needs to be set in the off state.
18	Left motor reverse	Set the rotation direction of the left motor. Set "ON" will reverse the rotation direction.
19	Right motor reverse	Setting the rotation direction of the right motor. Set "ON" will reverse the rotation direction.

### 5.10 Remote control key learning function

In the power off state, press the  key and  key at the same time, then press the power key  to power on the controller. The controller now enters the parameter configuration mode.

At this time, the key learning is in the off state. Press  (Neutral button) for a long time to switch the key learning to the on state. Now press the unlock button on the remote controller to complete the key learning, and the display shows that the learning is done. Press the power switch  to turn off the power and exit configuration mode. The controller can only learn one remote control key. Linking a new remote control key will override any previously linked remote control key.

The key learning state cannot be active in the locked state.

## 5.11 Controller Troubleshooting

The controller monitors the motor, Accelerator lever, etc., and displays the fault information when there is a fault preventing the scooter from running. The controller can only display a maximum of 3 faults.

### 5.11.1 Faults and troubleshooting methods

No.	Fault	Reason	Method
1	Left solenoid fault	Left motor electromagnetic brake switch not closed	Close the left motor red electromagnetic brake lever
		Left motor electromagnetic brake connection error	Verify that the motor interface is connected reliably
		Left motor brake electromagnetic brake failure or controller failure	Contact the manufacturer for maintenance
2	Right solenoid fault	Right motor electromagnetic brake switch not closed	Close the right motor red electromagnetic brake lever
		Right side motor electromagnetic setting scooter connection is wrong.	Verify that the motor interface is connected reliably
		Right motor brake electromagnetic brake failure or controller failure	Contact the manufacturer for maintenance
3	Left hall fault	Motor wiring error	Verify that the motor interface is connected reliably
		Motor Hall or controller failure	Contact the manufacturer for maintenance
4	Right hall fault	Motor wiring error	Verify that the motor interface is connected reliably
		Motor Hall or controller failure	Contact the manufacturer for maintenance
5	Left overcurrent	Excessive scooter resistance causes overflow.	The system will resume automatically after the Accelerator is released.
		Motor or controller failure	Contact the manufacturer for maintenance
6	Right overcurrent	Excessive scooter resistance causes overflow.	The system will resume automatically after the Accelerator is released.
		Motor or controller failure	Contact the manufacturer for maintenance
7	Acceleration not zero	The Accelerator lever is not at zero point during power on self-test	Release Accelerator and restart the controller
		Controller failure	Contact the manufacturer for maintenance
8	Acceleration fault	Accelerator lever or controller faulty	Contact the manufacturer for maintenance
9	MController not support	Motor controller failure or mismatch	Replace lower controller
10	Com fault Dis to MC	Loose or incorrect connection	Verify that the connection is correct and reliable
		Controller failure	Contact the manufacturer for maintenance

11	Com fault MC to Dis	Loose or incorrect connection	Verify that the connection is correct and reliable
		Controller failure	Contact the manufacturer for maintenance
12	Left driver fault	Motor controller failure	Contact the manufacturer for maintenance
13	Right driver fault	Motor controller failure	Contact the manufacturer for maintenance
14	Push rod Fault	Short circuit of brace motor output line or internal drive fault	Check brace motor interface or Contact the manufacturer for maintenance
15	Battery vol too high	Wrong battery is selected or the battery is fault.	Replace 24V Battery
16	Battery vol too low	Battery power is exhausted or fault	Charge or replace the battery
17	Angle sensor fault	Sensor faulty or wiring harness not connected properly	Contact the manufacturer for maintenance

## Chapter 6. Battery charging

**Note: If the mobility scooter is not used for a long period of time, it should be charged every 3 months to avoid permanent damage to the battery.**

Take the charger out of the bag, as shown in Figure 12 and connect the mains power lead to the charger.

### 6.1 Preferred Charging Method

**BEFORE** connecting the charger to the mains power, insert the charger's plug into the charging port under the digital display as shown in Figure 13. Now plug the charger into a mains power socket and turn on the power to start charging. Note: the charger will get hot during charging. It should be placed in a ventilated and dry place for charging, otherwise it may damage the charger.



Fig. 12



Fig 13

### 6.2 Alternative Charging Method

**BEFORE** connecting the charger to the mains power, connect the short charging adapter lead supplied to the charger's socket and then connect the other end of the adapter to an available connection on a battery, as shown in Figure 14. Now plug the charger into a mains power socket and turn on the power to start charging. Note: the charger will get hot during charging. It should be placed in a ventilated and dry place for charging, otherwise it may damage the charger.



Fig. 14



Fig 15

### 6.3 Charger Indicator Light

When the charger indicator is red, battery charging is taking place. When the light turns green, as shown in Figure 15, the battery is fully charged.

### 6.4 Automatic Charger Switch Off

When the power is almost exhausted, in order to protect the battery from excessive discharge, the controller and the battery itself will automatically turn off the power. **Note: when the battery indicator shows a low level, please do not drive in hazardous areas such as crossing the road.**

## Chapter 7. Storage and transportation of mobility scooters

### 7.1 Folding

Fold the mobility scooter and place it in a dry and ventilated place as shown in Figure 16. **Note: If the mobility scooter is not used for a long period of time, it should be charged every 3 months to avoid permanent damage to the battery.**

### 7.2 Lifting

If the scooter is lifted short distances, please use the positions shown in Figure 17. **Note: Do not pull the wires on the control box during transport, as shown in figure 18, as this may cause the wires to break or connections to become loose.**



Fig. 16



Fig 17



Fig. 18



Fig 19

### 7.3 Storage in a Vehicle

The mobility scooter can be folded and placed in the trunk of the car as shown in Figure 19. **Note: the temperature in the trunk of a car in hot summer weather may be more than 50°C. In hot conditions, the mobility scooter should be removed from the vehicle to avoid the risk of combustion.**

### 7.4 Storage on Public Transport

When taking the scooter on public transportation (such as airplane, high-speed rail, bus, etc.), all batteries should be removed and the scooter folded and packed for shipment, with the batteries being carried separately. **Note: The mobility scooter should be packed with protective measures to avoid damage during transportation, and the batteries should be carried to avoid them being damaged.**

## Chapter 8. Service and maintenance of mobility scooter

### 8.1 Routine inspection and maintenance

- Regularly (weekly or monthly, depending on the frequency of use) inspect the frame joints, such as screws and nuts, for looseness, corrosion, etc.
- Periodic inspection of any folding joints for seizure, wear and tear, and dislodgement.
- Lightly lubricate the two rods supporting the platform sliding mechanism
- Inspecting tyres regularly for ageing, cracking, and wear.
- If the mobility scooter is used in rain or wet weather, it should be wiped clean as soon as possible to avoid moisture and rust.
- Mobility scooters should avoid high temperatures as much as possible.

### 8.2 Replacement of consumable parts for mobility scooters

**8.2.1** Wearable parts of the wheelchair can be removed and replaced by using the manufacturer's accompanying tools, as shown in Figure 20.



Figure 20

**8.2.2** To replace the front tyre, as shown in Figure 21, remove the front wheel with on-board tool No. 5 wrench.



Fig. 21



Fig 22

**8.2.3** To replace the rear tyres, as shown in Figure 22, remove the rear wheel with the on-board tool No.5 wrench.

**8.2.4** Remove the seat and back cushions, as shown in Figures 23 and 24, by pulling the seat and back cushions apart by hand.



Fig. 23



Fig 24



### 8.3 Cleaning and disinfection

5.4.1 Clean the frame, motor, and controller with a cloth moistened with diluted detergent, taking care to apply appropriate but not excessive force and not to use abrasive or alcohol-based cleaners. Avoid excessive moisture on electrical connections.

5.4.2 After one month of use, the seat cushion and backrest should be wiped and checked for moisture or mildew, if any, it should be dried in the sun.

## Chapter 9. Troubleshooting

### 9.1 Fault phenomena and troubleshooting methods

Fault number	Fault phenomenon	Likely cause
1	Pressing the power switch button will not turn on the scooter	1. (a) Check that the controller and battery are connected. 2. (b) Check that the joystick is connected to the controller.
2	The battery cannot be charged	(a) The battery is not connected to the controller. (a) The battery is full and does not require charging. (a) The batteries are obsolete, contact the manufacturer for replacement batteries.
3	Mobility scooter drives slowly.	Low battery: please charge. Speed limit is too low. Adjust the speed limit button.
4	The range distance of scooter is insufficient.	Low battery: please charge. Battery is aging, contact the manufacturer to replace the battery
5	The front wheel shakes when driving	Worn or damaged bearings, replace bearings, contact manufacturer. 2. Screws loose, tighten screws.
6	Motor is noisy.	The gear is worn and needs to be replaced Bearings are worn and need to be replaced, contact the manufacturer.

For a description of any faults shown on the digital display, please refer to the section **Controller Troubleshooting**.

## Chapter 10. Mobility Scooter Parts

### 10.1 Complete vehicle parts diagram

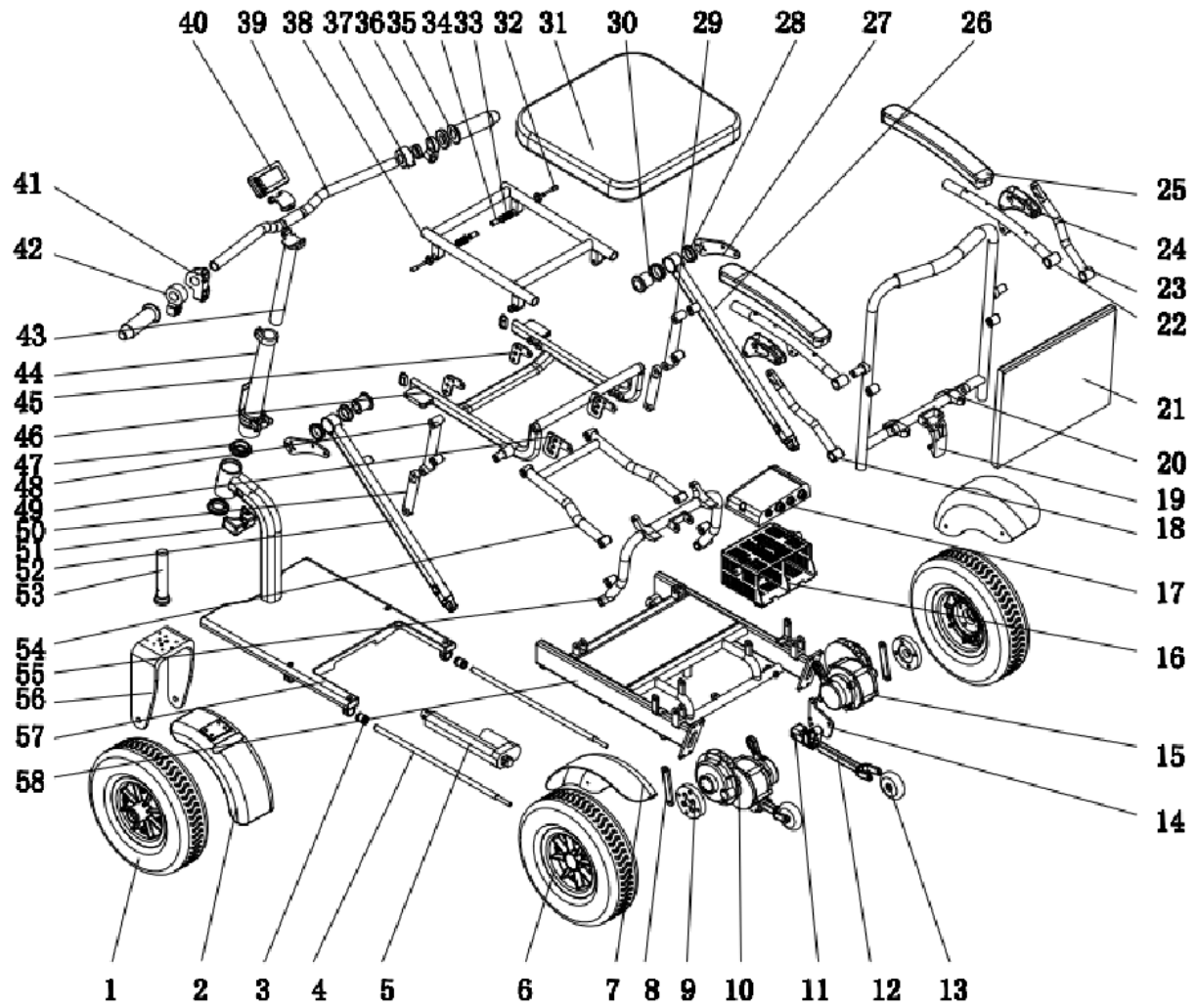

## 10.2 Names of vehicle components

Spare parts table for explosion drawing of small wheel scooter

No.	Part Name	Qty	Note	No.	Part Name	Qty	Note
1	9" front wheel	1		31	Cushion	1	
2	Fender for front wheel	1		32	Handl bar	2	
3	Sliding sleeve	4		33	Traffic control block 1	1	
4	Guide rod	2		34	Traffic control block 2	1	
5	Push rod	1		35	Handle frame	1	
6	10" rear wheel	2		36	Display screen	1	
7	Fender for rear wheel	2		37	Steering control block	1	
8	Fixed plate for fender	2		38	Control block of bottom frame expansion	1	
9	Fixed slice for fender	1L/1R		39	Upper handle support	1	
10	Left motor	1		40	Down handle support	1	
11	Anti-tipper lock	1L/1R		41	Seat frame	1	
12	Anti-tipper bar	2		42	Bearing set	1	
13	Anti-tipper wheel	2		43	Left upper connecting frame	1	
14	Connecting plate	2		44	Joint lever	2	
15	Right motor	1		45	Steering control box	1	
16	Battery box	1		46	Left rear frame	1	
17	Controller box	1		47	Verticle shaft	1	
18	Armrest support L	1		48	Connecting frame	1	
19	Latch	1		49	Down back frame	1	
20	Back frame	1		50	Fork	1	
21	Back cushion	1		51	Front bottom frame	1	
22	Armrest frame	2		52	Rear bottom frame	1	
23	Armrest support R	1					
24	Armrest lock	2					
25	Armrest pad	2					
26	Right rear frame	1					
27	Front connecting plate	1L/1R					
28	Nylon lining 40	4					
29	Right upper connecting frame	1					
30	Nylon lining	2					

### 10.3 Electrical schematics

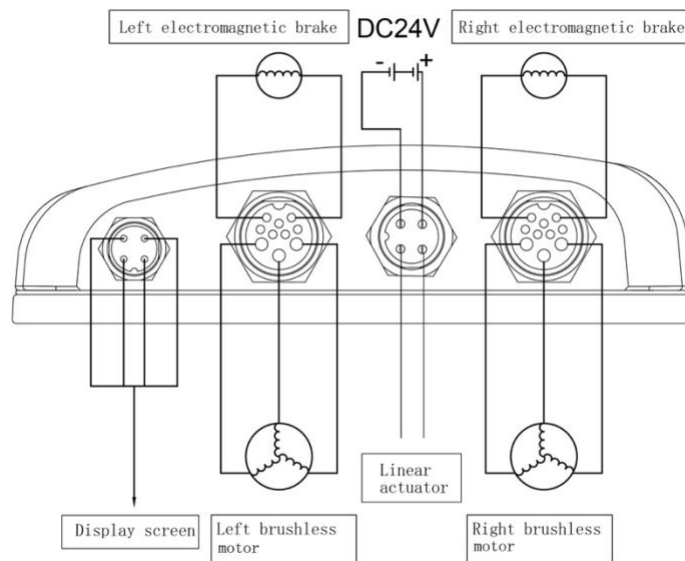
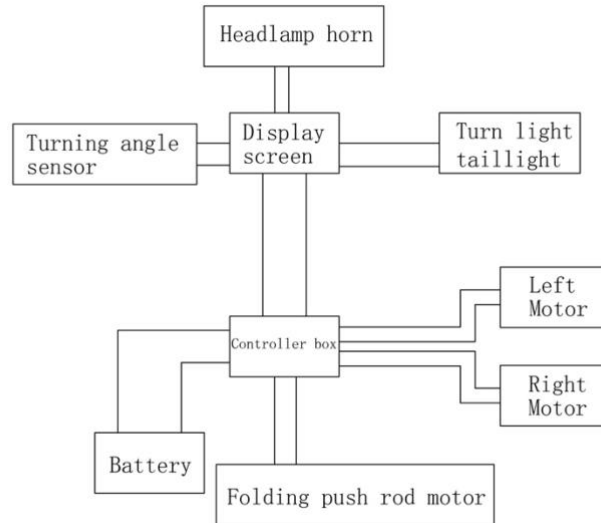

## 10.4 Specifications of the Controller

Specification Parameter Name	Parameter Value	Comments
Operating Voltage Range	23~30V	Powered by 24V battery, scooters beyond the voltage range cannot run.
Power off current	Less than 2mA	Power supply is turned off and the remote controller reception is active.
Standby current	Less than 120mA	Power on but not running
Motor drive current	20A	Each motor
Electromagnetic brake drive current	Max. 1A	The actual current is determined by that electromagnetic brake in motor
Push rod motor drive current	5A (Voltage Same as Battery Voltage)	
Remote control frequency	433.92MHz	
Remote control voltage	6V	Use two 2016 batteries
Remote control distance	More than 8 meters	Open ground, without interference
Operating temperature range	-20~50°C	
Storage temperature range	-30~70°C	
Operating humidity range	20%~80%	
Operating pressure range	860~1060 kPa	
Waterproofing grade	IPX4	
Motor PWM Drive Frequency	20kHz	

## 10.4.1 Revisions

Change Date	Version	Change Content
June 2020	V1.0	First edition

## Chapter 11. Environmental protection

### 11.1 Name and content of toxic or hazardous substances or elements.

Part name	Toxic substances or elements					
	(Pb)	(Hg)	(Cd)	[Cr(VI)]	PBB	(PBDEs)
Lithium Battery	○	○	○	○	○	○
motor	○	○	○	○	○	○
chargers	×	○	○	○	○	○
controllers	×	○	○	○	○	○
frame	×	○	○	○	○	○
seat pad	×	○	○	○	○	○
packing case	×	○	○	○	○	○
Specification	×	○	○	○	○	○

○: Indicates that the content of the toxic or hazardous substance in all homogeneous materials of the part is below the specified limit.  
 ×: Indicates that the content of the toxic or hazardous substance in at least one homogeneous material of the component exceeds the specified limit.

### 11.2 Treatment at the end of product service life

The discarded products should be handed over to the environmental protection department for recycling for harmless disassembly and recycling of recyclable materials.

## Chapter 12. Quality assurance

### Product Warranty

Repair within the warranty period will require proof of purchase. Out-of-warranty repairs will be charged for and the customer will be responsible for shipping costs.

Warranty coverage	Warranty period	Note
Frame	2 years	Non-deliberate damage
Electric motor	1 year	Non-deliberate damage
Batteries	1 year	Non-deliberate damage
Chargers	1 year	Non-deliberate damage
Controllers	1 year	Non-deliberate damage
Wearable part	3 months	Non-deliberate damage of: Front and rear tyres, seat back pad, armrest surface, footrest pad

## Warranty card

User information	User Name		Phone Number	
	contact address			
Product information	Model Number		Product serial number	
	Date of purchase		Purchase voucher number	
Retailer information	Retailer Name		Retailer's Stamp	
	Phone Number			
Service date	Maintenance personnel	Maintenance records		

## Manufacturer's details

Kunshan Aoshida Electric Technology Co.,Ltd  
 Add:108 Matang Road, Development Zone, Kunshan City, Jiangsu Province 215333, China  
 Tel: +086-0512-57816288 Fax: +086-0512-57816388  
 Website: www.freedom-chair.com

## UK &amp; Ireland Distributor

Proactive Mobility Ltd  
 Silverstone House  
 Kineton Road  
 Gaydon  
 Warwickshire  
 CV35 0EP  
 Phone: 0330 555 5225  
 Email: info@proactivemobility.com  
 Web: www.e-goes.co.uk